



60 WATT HLE SERIES

INSTALLATION INSTRUCTIONS



HLE-1 Driver

Refer to the wiring diagrams when connecting field wiring.

Regulatory Agency Listings:

UL: File E27820, Guide VCSV

CSA: Guide 386-0



MODEL	POWER RATING	VOICE COIL IMPEDANCE
HLE-1	60 Watts	16 Ohms
HLE-3	60 Watts	16 Ohms

The back cover of the explosion-proof driver enclosure must be removed for access to the field connections. Exercise special care when removing the back cover to avoid damaging the machined surfaces.

Prior to re-assembly, make certain that the joining surfaces of the enclosure are free of any foreign matter that would interfere with proper mating of the machined surfaces. Tighten all bolt cover bolts completely.

NOTE: To provide the specified protection in hazardous locations, do not apply any type of compound/sealant to the machined flange.

The HLE-1 and HLE-1T does not include a factory installed pipe seal. The installer must provide an appropriate connector as directed by local codes or authority having jurisdiction. A pipe seal with integral field wiring leads is included with the HLE-3 and HLE-3T

The models HLE-1T and HLE-3T include an integral line matching transformer.

UNDERWRITERS' LABORATORY LISTINGS		
DRIVER	CLASS/GROUP	FOR ATMOSPHERE CONTAINING:
HLE-1(T)	Class 1/ Group C and D	Gas Atmospheres (Including Ethyl, Gasoline, Naphtha, Ether, Butane, Alcohols, Propane)
HLE-3(T)	Class 1/ Group B, C, and D	Gas Atmospheres (Including Ethyl, Ether, Gasoline, Naphtha, Alcohols, Butane, Propane) Hydrogen, Gas and Vapor, (Manufactured Gas)

IMP. OHMS	W 70V IN	W 25V IN
45	Do Not Use	15.0
85	60	7.5
125	40	5
250	20	2.5
500	10	1.25
1000	5	.625
2000	2.5	.312

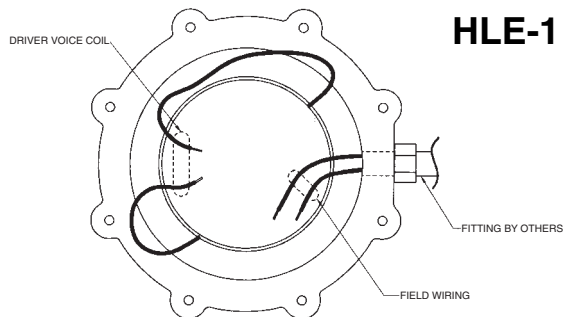
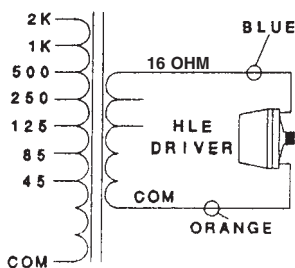

HLE-1

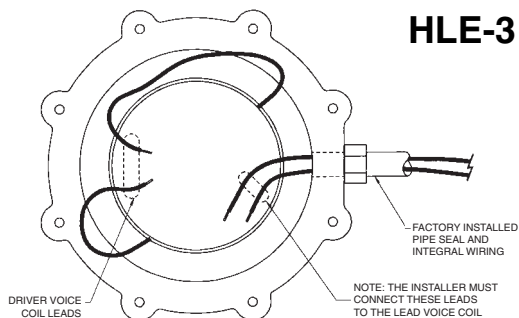

HLE-3

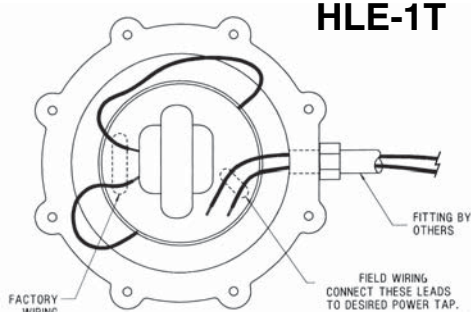

HLE-1T

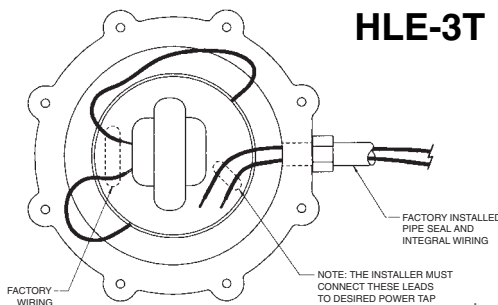

HLE-3T

Specifications are subject to change without notice



www.AtlasSound.com

1601 JACK MCKAY BOULEVARD ENNIS, TEXAS U.S.A. • TELEPHONE: (800) 876-3333 • FAX: (800) 765-3435

© 2005 ATLAS SOUND LP

Printed in U.S.A.

01205

ATS002236 RevB 12/05

PN 420433