

MARKING METHODS, INC.®

301 SOUTH RAYMOND AVENUE
ALHAMBRA, CA 91803-1531

626-282-8823

FAX 626-576-7564

Email: experts@markingmethods.com

Website: www.markingmethods.com

**MANUAL FOR
ELECTRO-CHEMICAL
MARKING, EQUIPMENT
& SUPPLIES**

**ATTENTION:
PLEASE READ MANUAL
CAREFULLY BEFORE
OPERATING EQUIPMENT**

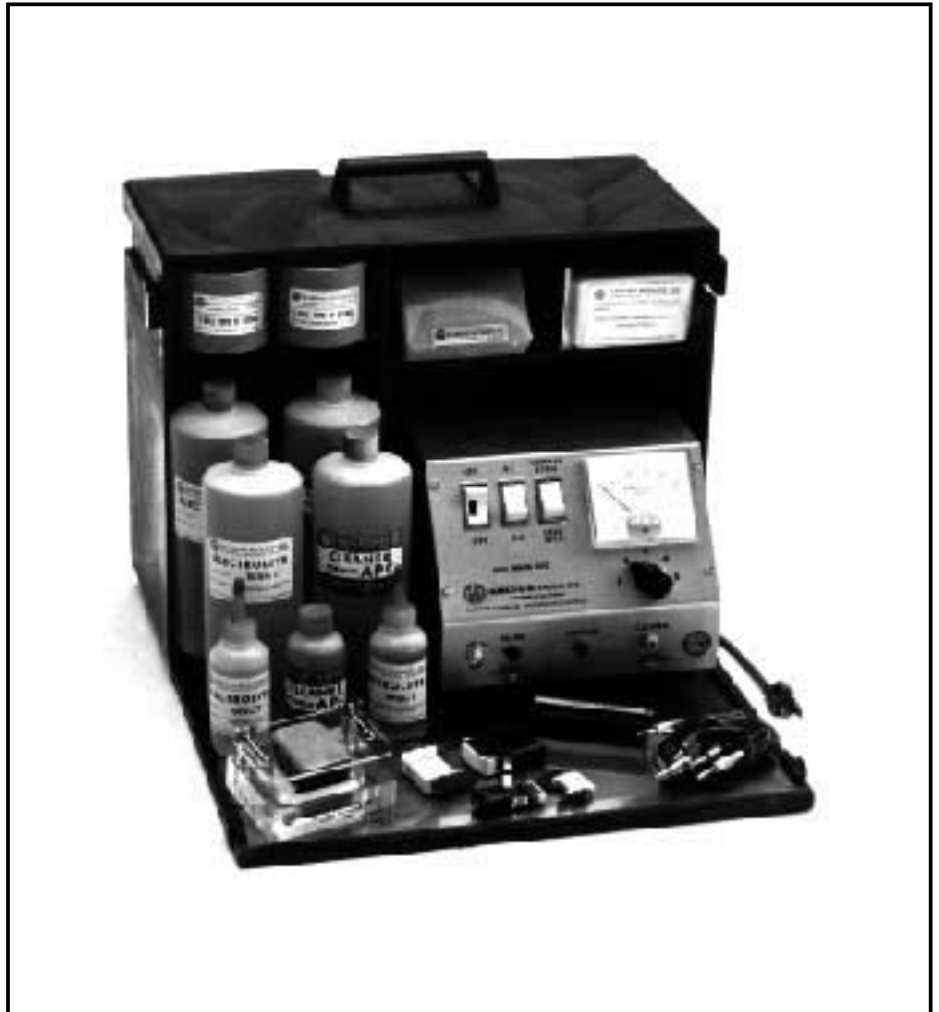

MARKING METHODS, INC.®

MODEL MARK 300 (SERIES)

- **EQUIPMENT**
- **OPERATION**
- **ELECTROLYTE CHART**
- **SUPPLIES**

WHAT IS ELECTRO-CHEMICAL MARKING?

ELECTRO-CHEMICAL MARKING is the process used for stress free permanent marking on all conductive metals. The process is economical, simple, fast and safe. The one restriction to this process is that it will not function on painted parts, already anodized aluminum or through certain heavy phosphate coatings. However, by deep etching the parts prior to any of these non-conductive coatings, the mark shows through very legibly. This allows positive traceability throughout the life of the parts.

MARKING METHODS' complete MARK 300 (SERIES) Electro-Chemical marking system is designed to provide maximum performance and ease of operation. The assembly includes all the necessary equipment and supplies to most effectively mark all parts....from tiny semiconductors to massive aircraft and aerospace components. Depth of mark from one ten thousandth (.0001) of an inch deep for feeler and plug gages to ten thousandths (.010) deep for absolute traceability of parts is easily attainable.

The power unit is equipped with an AC-DC switch. The AC (alternating current) alternately etches out and redeposits back a combination of the metal oxide and electrolytic salts producing a black mark. The DC (direct current) charges the applicator negatively (cathodic) which dissolves metal out, etching a frosted or clear mark. To prevent corrosion, the parts must be thoroughly cleaned after marking to remove any residual salts. No special skill is required to operate the equipment except pride in doing a good job. Electro-Chemical marking does not deform, weaken or fracture the metal because molecular structure is not altered beyond the depth of the mark. Methods such as steel stamping, electric arc etching or vibratory marking alter the grain structure of the metal in the area of the mark causing possible stress or fracture to the parts.

HOW DOES THE PROCESS WORK?

A controlled depth, permanently etched mark of any design or detail is made by the operator on metal surfaces in a matter of seconds. It is simply made by placing the MARKING APPLICATOR (A) over the STENCIL (B) in contact with the PART (C) to be marked. The part is positioned on a GROUND PLATE (D) to complete the electrical current. The current and the electrolyte fluid do the rest – in seconds! A permanent mark is the result which can only be removed by buffing or grinding the metal down to the depth of the mark. Occasional blotting of the applicator in the STENCIL CLEANER TRAY (E) replenishes the electrolyte supply and helps to keep the stencil apertures clean.

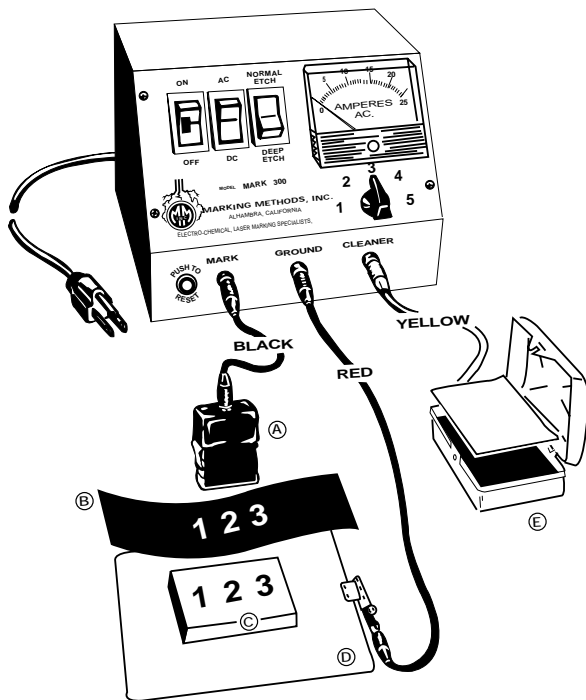

NORMAL-ETCH

INSTRUCTIONS for using MARK 300 POWER UNIT

- (1) Plug the line cord connected to the power unit into a grounded 110/120 VAC outlet only. Converters are available for 220/240 VAC.
- (2) Plug the BLACK cord into the BLACK (MARK) receptacle; the opposite end of the cord into the HAND PAD.
- (3) Plug the RED cord into the RED (GROUND) receptacle; the opposite end to the GROUND PLATE or attach the alligator clip directly to the part to be identified.
- (4) Plug the YELLOW cord into the YELLOW (CLEANER) receptacle; the opposite end to the STENCIL CLEANER TRAY.
- (5) Set the AC-DC Switch on AC position for most metals and DC for Aluminum and Black Oxide. AC produces a black mark; DC produces a frosted or clear mark.
- (6) Set the Normal/Deep-Etch Switch on NORMAL.
- (7) Set the Rheostat on No. 5. If the mark is blurred, turn the Rheostat to a lower position.
- (8) Place a clean Hand Pad Screencloth on the Hand Pad. Saturate the Screencloth with the proper Electrolyte. Select the proper Electrolyte from the chart on page 5. Refer to applicable MSDS for safety information.
NOTE: Fresh Electrolyte and a clean Screencloth are essential. Saturate the Cleaner Tray Wick with the same Electrolyte used on the Screencloth. Blot the Hand Pad in the Cleaner Tray to add fresh Electrolyte. Use paper towels to blot off any excess Electrolyte on the Screencloth. (It should be saturated but not dripping).
REPLACE SCREENCLOTH WHEN IT BECOMES CONTAMINATED OR FAILS TO GIVE GOOD SHARP MARKS.
- (9) Position the Stencil on the part to be identified so the legend reads correctly and hold securely so the legend does not move.*
NOTE: If the Stencil is positioned on the Hand Pad for a single blot, the legend should read reversed and be secured by a Retainer Ring.
- (10) Set the ON-OFF Switch to ON position.
- (11) Blot over the legend in the Stencil with the Hand Pad for approximately 2 seconds, then break contact by raising the Hand Pad from the part momentarily. Continue the procedure until the desired darkness and/or depth is obtained.
- (12) To clean Stencil during marking, place the Stencil on the Cleaner Tray Wick and blot over the image with the Hand Pad.
- (13) After the desired darkness or depth is reached, remove the Stencil from the part and using the APC Cleaner, thoroughly clean the part with a clean shop cloth by using a rubbing action, making sure that none of the Electrolyte is left on the part.
NOTE: For best results pour some of the Cleaner into a small open container instead of using the Cleaner from the bottle. This will prevent contamination of the fresh Cleaner. Parts may also be immersed in the APC Cleaner.
CAUTION: IF THE PARTS ARE IMMERSED, CHANGE CLEANER WHEN IT BECOMES CONTAMINATED WITH ELECTROLYTE. WHEN THIS HAPPENS THE CLEANER WILL BECOME CLOUDY.
- (14) After cleaning the part, dry it thoroughly with a clean, dry cloth.**
- (15) After the marking is completed, turn the ON-OFF Switch to OFF. Unplug the BLACK, RED and YELLOW cords from their receptacles.
- (16) Remove the Screencloth from the Hand Pad and flush thoroughly with cold water. The Screencloths are reusable if they rinse out reasonably clean.
- (17) With water, thoroughly rinse the Hand Pad, Retainer Ring, Insulator, Ground Plate and any other material that came in contact with the Electrolyte.
- (18) Dry the above mentioned items with a clean dry cloth.
- (19) Discard all used Electrolyte and Cleaner.
NOTE: Never pour used Electrolyte or Cleaner back into the bottles as the oxidation from the parts will contaminate the fresh solutions.
- (20) After all these steps have been followed, your equipment and supplies will be ready for use the next time.

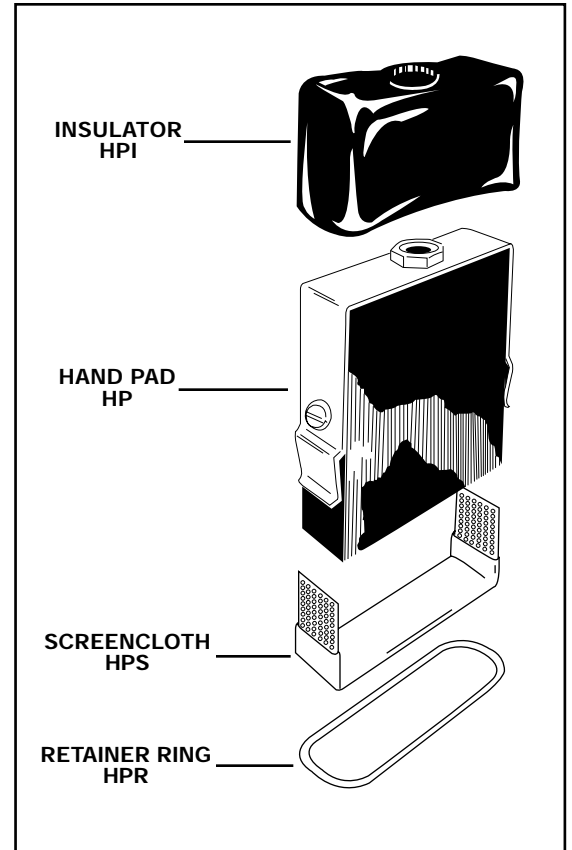

* See back cover for Die-Impression Stencil instructions.

** Use CPO or WSP for highly corrosive metal parts, after cleaning and drying part.

DEEP-ETCH

INSTRUCTIONS for using MARK 300 POWER UNIT

- (1) Plug the line cord connected to the back of the power unit into a 110/120 VAC outlet only. Converters are available on request for 220/240 VAC.
- (2) Plug the BLACK cord into the BLACK (MARK) receptacle; the opposite end of the cord into the Deep-Etch Hand Pad.
- (3) Plug the RED cord into the RED (GROUND) receptacle; the opposite end to the Ground Plate or attach the alligator clip directly to the part to be identified.
- (4) Plug the YELLOW cord into the YELLOW (CLEANER) receptacle; the opposite end into the STENCIL CLEANER TRAY receptacle.
- (5) Set the AC-DC Switch on DC position.
- (6) Set the Normal/Deep-Etch Switch on DEEP-ETCH.

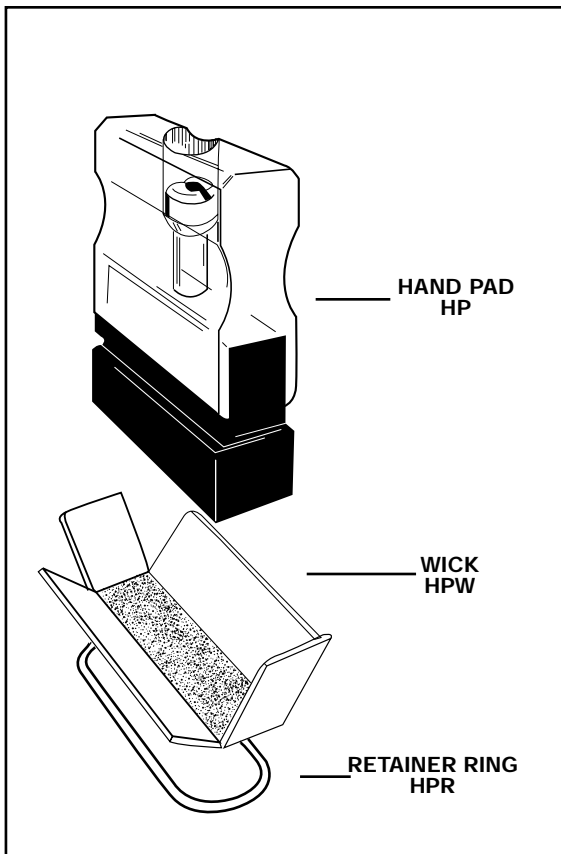

- (7) Set the Rheostat to No. 3.
- (8) Set the ON-OFF Switch to ON position.
- (9) Place a clean Wick on the Deep-Etch Hand Pad and secure the Wick with a Retainer Ring. Saturate the Wick with the proper Electrolyte. (Select the proper Electrolyte from the Deep-Etch column of the chart on page 5). NOTE: Fresh Electrolyte and a clean Wick are essential. Saturate the Cleaner Tray Wick with the same Electrolyte used on the Wick. Blot the Hand Pad in the Cleaner Tray to add fresh Electrolyte. Use paper towels to blot off any excess Electrolyte. USE A DEEP-ETCH WICK PAD FOR EACH ONE OR TWO PARTS.
- (10) Position the Stencil on the part to be identified so that the legend reads correctly and hold securely so the legend does not move.*
- (11) Blot over the Stencil with the Hand Pad 4 or 5 times, then dip the Hand Pad into the Cleaner tray. The dwell time for each blotting should be approximately 2 to 3 seconds on, then break contact by raising the Hand Pad from the part momentarily. Continue the procedure 15 to 20 times or until the desired depth is obtained. (.003 to .006" deep normally takes from 1 to 2 minutes.)** NOTE: Be sure the Stencil is held securely and does not move during marking as this can cause multiple marks. The blotting action should be as follows: 2 to 3 seconds dwell ON the part, 1 second OFF the part. This allows the gases to escape and affords a pulsing effect.
- (12) After the desired depth is obtained, remove the Stencil from the part and using the APC Cleaner, thoroughly clean the part with a shop cloth by using a hard rubbing action, making sure that none of the Electrolyte is left on the part. NOTE: For best results pour some of the Cleaner into a small open container instead of using the Cleaner from the bottle. This will prevent contamination of the fresh Cleaner.
- (13) After cleaning the part thoroughly, dry it with a clean dry cloth.***

- (14) To clean the Stencil before marking the next part, place the Stencil on the Cleaner Tray Wick and blot over the image with the Hand Pad.
- (15) After the marking is completed, turn the ON-OFF switch to OFF. Unplug the BLACK, RED and YELLOW cords from their receptacles.
- (16) Remove the Wick Pad from the Hand Pad and DISCARD ALL USED WICKS.
- (17) Take the Hand Pad, Retainer Ring, Ground Plate and any other material that came in contact with the Electrolyte and rinse thoroughly with water.
- (18) Dry the above mentioned items with a clean dry cloth.
- (19) Discard all used Electrolyte and Cleaner.
NOTE: Never pour used Electrolyte or Cleaner back into the bottles as the oxidation from the parts will contaminate the fresh solutions.
- (20) After all these steps have been followed, your equipment and supplies will be ready for next time.

* See back cover for Die-Impression Stencil instructions.

** To produce a DARK Deep-Etch mark, set the AC-DC Switch on AC position and the Normal/Deep-Etch Switch on NORMAL ETCH. Blot over the Stencil again using fresh Electrolyte on the Hand Pad. This is done after the desired depth is achieved.

*** Use CPO or WSP for highly corrosive metal parts, after cleaning and drying part.

BENCH FIXTURES

INSTRUCTIONS for using BF1520, BF2045 & BF4060 BENCH FIXTURES with MARK 300 POWER UNIT

(NORMAL ETCH ONLY)

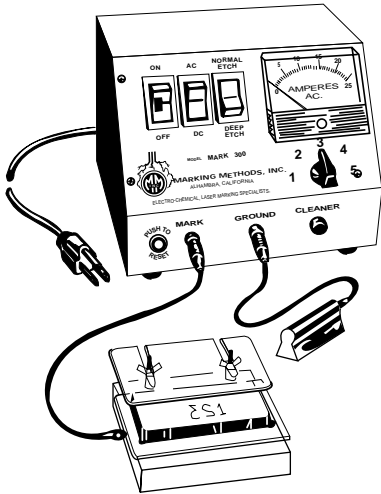

- (1) Plug the line cord connected to the back of the Power Unit into a 110/120 VAC outlet only. Converters are available on request for 220/240 VAC.
- (2) Plug the BLACK cord into the BLACK (MARK) receptacle: the opposite end of the cord into the Bench Fixture.
- (3) Plug the RED Cord into the RED (GROUND) receptacle; slide the alligator clip off the opposite end and slide on the Hand Ground.
- (4) Set the AC-DC Switch on AC for most metals and DC for Aluminum and Black Oxide. AC produces a black mark; DC produces a frosted or clear mark.
- (5) Set the Normal/Deep-Etch Switch on NORMAL.

- (6) Set the Rheostat on No.5. Note: If the mark is blurred, turn the Rheostat to a lower position.
- (7) Place a clean Wick Pad on the graphite block in the Bench Fixture (green side down) and secure the Wick with a Retainer Ring.
- (8) Saturate the Wick Pad with the proper Electrolyte. Select the proper Electrolyte from the chart on page 5.
- (9) Place Stencil with the legend reading REVERSED over Wick Pad and secure a second Retainer Ring. (Stencil may also be secured by a Locating Plate, which is milled to fit the part).*
- (10) Set the ON-OFF Switch to ON position.
- (11) Place part to be marked in fixture and ground by touching part with either the Hand Ground, Finger Ground, or with the alligator clip. NOTE: Etching may be accomplished by rolling the part across the stencil with Hand Ground or by placing the part in the Locating Plate and grounding with the Hand Ground or Finger Ground.
- (12) After marking each part, thoroughly clean the parts with APC Cleaner by wetting a clean shop cloth with the Cleaner and rubbing the part, making sure that none of the Electrolyte is left on the part, or by immersing the part in a small open container filled with APC Cleaner.
- (13) After cleaning the parts thoroughly, dry them with a clean dry cloth.
- (14) After marking is completed, turn the ON-OFF switch to OFF. Unplug the BLACK and RED cords from their receptacles.
- (15) Remove the Wick Pad from the graphite block and wash thoroughly with water. Wick Pads are reusable if they wash out reasonably clean.
- (16) With water, thoroughly rinse the Bench Fixture, Retainer Rings, Hand Ground and any other material that came in contact with the Electrolyte.
- (17) Dry the above mentioned items with a clean, dry cloth.
- (18) Discard all used Electrolyte and Cleaner. NOTE: Never pour used Electrolyte and Cleaner back into the bottles as the oxidation from the parts will contaminate the fresh solutions.
- (19) After all these steps have been followed, your equipment and supplies will be ready for use the next time.

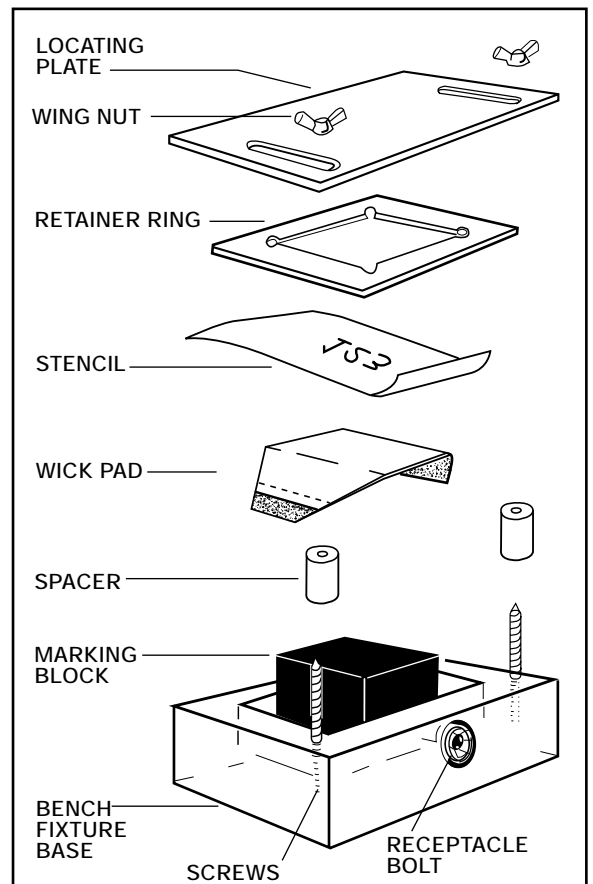

* See back cover for Die-Impression Stencil instructions.

ELECTROLYTES

MARKING METHODS' laboratory controlled Electrolytes are the result of years of research and development. They are carefully formulated and cataloged by formula and batch number to mark varied metals and surface treatments. The Electrolytes are buffered salt solutions, pH balanced, and are completely harmless to parts and surrounding equipment when used as directed.

METALS, ALLOYS & PLATINGS	ELECTROLYTE FOR NORMAL ETCH	POWER UNIT SETTING	COLOR OF MARK	ELECTROLYTE FOR DEEP ETCH*	COMMENTS
Aluminum (most alloys)	A10	DC	Black	MSC1	Allow a few seconds for color to develop before cleaning
Aluminum with high magnesium or silica	MSC1, MSC5	DC	White	MSC1	Black not possible unless lacquer filled
Aluminum (to be anodized)		DC	Black	MSC1	Deep etch BEFORE anodizing (minimum .002)
Aluminum Bronze	B20, B10	AC	Black	MSC3, MSC5	
Beryllium	B20, MSC7, F10	AC	Black	MSC3, MSC5	Reduce amperage if blurring occurs
Beryllium Copper	B20	AC	Black	MSC3, MSC7	
Black Oxide on Steel	MSC3, F30	DC	White		Use low amperage, oil part after cleaning
Black Oxide on Stainless	MSC1	DC	White		Use low amperage
Black Phosphate	F30	DC	White		If coating is heavy, parts should be deep etched
Brass & Bronze	B20, MSC5, B10	AC	Black	MSC3, MSC5	
Cadmium Plate on Steel	MSC5, B20, B10, F20	AC	Black		Allow time for oxide to stabilize before cleaning
Carbides	C30, C10, MSC4	AC	Black	F30	
Chrome Plate-hard	MSC1, MSC7	DC	Clear	F30	Blotting action improves frosted contrast
Chrome Plate-decorative	MSC1, MSC4, MSC7	AC	Black		
Cobalt Alloys, Stellites	MSC1, F10, F30, MSC7	AC	Black	MSC7, MSC4	
Copper & alloys	B20, B10, MSC3, MSC5	AC	Black	MSC5, MSC3	
Copper Nickel (cupro-nickel)	MSC5, F30, F20, B20	AC	Black		
Damascus	C10, MSC4	AC	Dark	C10, MSC4	
Discaloy	MSC4, F30	AC	Black		
Dow coating (Parkerized)		DC	Clear	C10	Deep etch BEFORE unless coating is very thin
Electroless Nickel Plate	MSC7 OR F30	AC	Dark		
Gold and Gold Plate	MSC1, F10, C10	AC	Dark		Dark mark usually not stable
Gold and Gold Plate		DC	Clear	MSC1, F10, C10	
Hastelloy	MSC4, MSC3, F20	AC	Black	MSC4	
Haynes 25 (Stellite)	MSC7, MSC1, MSC4	DC	Clear	MSC7	
Haynes 188	MSC5, F10	AC	Black	MSC7	
Inconel	MSC4, C10, F20	AC	Black	MSC4	
Inconel 718 & 750	MSC4, F30, F10	AC	Black	MSC4, 59NC	
Invar	MSC4, MSC7, MSC1, F30	AC	Dark		
Iron	MSC4, F10	AC	Black	MSC4	
Lead and alloys	MSC3, F30	AC	Black		
Magnesium & alloys	MSC5, MSC1	AC	Clear	MSC1	Use minimum amount of Electrolyte (work dry)
Molybdenum	F10, C10	AC	Black		
Monel & K Monel	MSC1, C10	AC	Black		
Nickel & alloys	MSC7, F30	AC	Black		
Nickel Plating on Brass & Copper	MSC7, B20, C10	AC	Black		
Nickel Plating on Steel & Aluminum	MSC4, F30, F20	AC	Black		
Nickel Silver	MSC5, B20, F20	AC	Black		Use high amperage
Niobium	MSC3, T10	AC	Dark		
Nitaloy	MSC4, C10	AC	Black		
Silver & Sterling		DC		B10	
Silver Plate	MSC8, B10	AC	Black	B10	Use low amperage, work dry, wait before cleaning
Sintered Copper Tin	B10, B20	AC	Black		
Stainless Steel (300 & 400 series)	MSC1, MSC4, MSC7, B20	AC	Black	MSC1	
Steels-low carbon & mild	MSC4, MSC1, C10, B20	AC	Black	MSC4, C10, MSC1	
Steels-high alloy, tool & saw steel	MSC4, C10	AC	Black	MSC4, C10	
Tin & Tin Plate	MSC5, F20	AC	Black		
Titanium	T10, MSC7, C10	AC	Dark	MSC3, F30, F20	Use low amperage & minimum Electrolyte
Titanium Nitrate	MSC2	AC	Dark		Use low amperage & minimum Electrolyte
Tungsten (pure)	T10, F20, C30	AC	Dark	B10, 59NC, MSC3, F30	Use DC if AC not dark enough & minimum Electrolyte
Tungsten Carbide	C30, MSC4	AC	Dark		Use DC if AC not dark enough
Waspaloy	MSC3, B10	AC	Dark		
Zinc & Zinc Plate	MSC2, MSC1, B10, F20	AC	Black		
Zirconium	T10, C10	AC	Dark	MSC1	Allow time for oxide to stabilize before cleaning

See applicable MSDS for safety information.

COPYRIGHT © 1975

MARKING METHODS, INC. ® ALHAMBRA CA 91803-1531 • 626-282-8823 • FAX 626-576-7564 • email: excellence@markingmethods.com • VISIT OUR WEB SITE AT: www.markingmethods.com

NUCLEAR GRADE ELECTROLYTES (non-chloride or halogen free) can be furnished that contain less than 250 ppm of chlorides (halogens), sulfur, mercury, copper, zinc, and lead. These Electrolytes can be certified to meet MIL STD's 767 and 792 when requested. Use a light oil film (CPO) prior to marking on sand or grit blasted surfaces to prevent blurring. Oil fills the open grain surface of the metal. This procedure is also very effective before marking metals or plating that stain easily. Do not use gold (DF2) stencil for this application. Submit sample parts to our laboratory for Electrolyte evaluation of particularly difficult applications. *NOTE: POWER UNIT SETTINGS FOR ALL DEEP ETCH MARKING SHOULD BE DC AND DEEP ETCH WITH RHEOSTAT AT 3 OR HIGHER. AMPLE ELECTROLYTE MUST ALWAYS BE USED. DEEP ETCHING MAY PRODUCE A FUZZY OR BLURRED MARK. A LIGHT BUFFING AFTER CLEANING WILL SHARPEN THE LINE DEFINITION.

REPLACEMENT PARTS and HAND PAD ACCESSORIES

Dimensions are actual marking area of applicator

NORMAL ETCH (Pkg. of 10)

HP12575	HAND PAD	1/8" x 3/4"	SCREENCLOTH	HPS12575
HP12515	HAND PAD	1/8" x 1-1/2"	SCREENCLOTH	HPS12515
HP2575	HAND PAD	1/4" x 3/4"	SCREENCLOTH	HPS2575
HP2515	HAND PAD	1/4" x 1-1/2"	SCREENCLOTH	HPS2515
HP515	HAND PAD	1/2" x 1-1/2"	SCREENCLOTH	HPS515
HP1020	HAND PAD	1" x 2"	SCREENCLOTH	HPS1020

DEEP ETCH (Pkg. of 10)

HP2575DE	HAND PAD	1/4" x 3/4"	WICKS	HPW2575DE
HP515DE	HAND PAD	1/2" x 1-1/2"	WICKS	HPW515DE
HP1020DE	HAND PAD	1" x 2"	WICKS	HPW1020DE

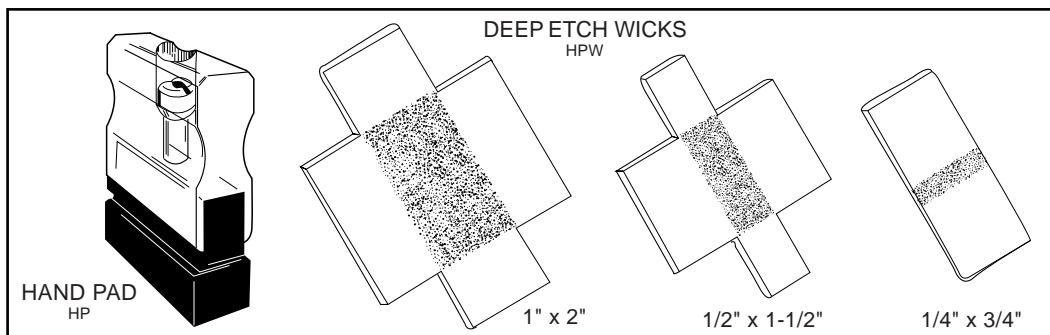

BENCH FIXTURE WICK PADS

BF1520-3	BENCH FIXTURE WICK PAD 1-1/2" x 2" (Pkg. of 10)
BF2045-3	BENCH FIXTURE WICK PAD 2" x 4-1/2" (Pkg. of 10)
BF4060-3	BENCH FIXTURE WICK PAD 4" x 6" (Pkg. of 10)

OTHER ACCESSORIES

CT2535	STENCIL CLEANER TRAY
CT2535-3	STENCIL CLEANER TRAY WICK PADS (Pkg. of 10)

DIE-IMPRESSION STENCILS

DIRECTIONS FOR USE: Use a typewriter set on "stencil" position. Type on colored side of stencil with backing underneath. Remove backing to mark with stencil.

ROLLS

RO2B5	2-1/2 inch x 20 feet (Heavy duty opaque BLUE)
R05B5	2-1/2 inch x 750 feet (Heavy duty opaque BLUE)
R09B5	3-3/4 inch x 20 feet (Heavy duty opaque BLUE)
R12B5	3-3/4 inch x 750 feet (Heavy duty opaque BLUE)
R02A3	2-1/2 inch x 20 feet (Heavy duty opaque GREEN)

BOXES (100 sheets per box)

L07B5	3 inch x 6 inch (Heavy duty opaque BLUE)
L01B5	2-1/2 inch x 7 inch (Heavy duty opaque BLUE)
L08B5	3-3/4 inch x 7 inch (Heavy duty opaque BLUE)
L01A3	2-1/2 inch x 7 inch (Heavy duty opaque GREEN)

CORD SET

300	3-WIRE COLOR-CODED CORD SET Standard length is 3-1/2 ft., but may also be ordered in a 6 ft. length (300-6), 8 ft. length (300-8), etc.
-----	--

ELECTROLYTES

SEE CHART Available in quart bottles, 12-quart cases, 5 and 55-gallon containers. Refer to the **ELECTROLYTE CHART** on page 5 for recommended formulas.

CLEANERS

APC	An ALL PURPOSE CLEANER (light amber color)
APCW	Parts cleaning wipes pre-moistened with APC cleaner
NO90	CONCENTRATED CLEANER (Milky white color) has a light oil base that leaves a protective film on parts. (Recommended when cleaning corrosive metal parts).
CPO	CORROSION PREVENTATIVE OIL is an excellent in-plant oil for protection of parts after they have been marked, cleaned and dried (only necessary for use on parts that require protection from normal atmospheric conditions).
WSP	WATER SOLUBLE PROTECTANT is used in same application as CPO but contains no solvent base.

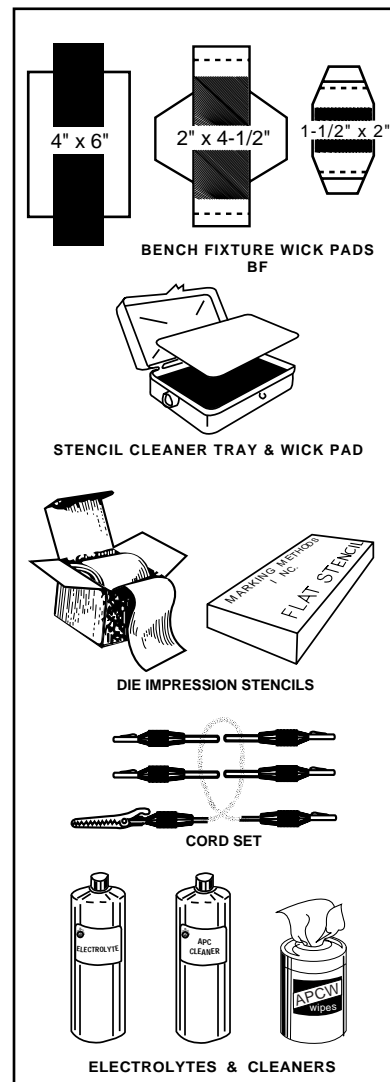
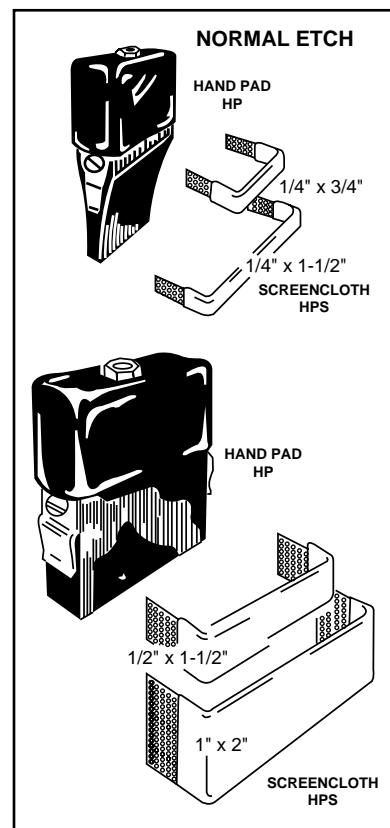

SPECIAL INSTRUCTIONS and ANSWERS TO PROBLEMS

- PARTS BECOME FOGGY, CORRODED, CONTAMINATED OR BROWN FINGERPRINTS APPEAR. Parts were improperly cleaned. Use APC Cleaner. NEVER oil parts without cleaning & drying first.
- MARK IS NOT LEGIBLE OR DARK ENOUGH. Incorrect Electrolyte. Incorrect current setting. Dwell time too short.
- MARK ON ALUMINUM DISAPPEARS AFTER ANODIZING. Part must be DEEP-ETCHED a minimum of .002" deep prior to anodizing. Part cannot be marked after anodizing.
- BLACK OXIDE WHITE MARK IS NOT LEGIBLE OR IS INCOMPLETE. Try a different Electrolyte. Rub a light abrasive over mark. Use DC current.
- DEEP ETCH REQUIRES A DARK MARK. After etching desired depth and before moving stencil, switch DC to AC and DEEP ETCH to NORMAL ETCH. Then blot several more times.
- POWER UNIT INDICATOR LIGHT GLOWS BUT NO MARK IS MADE. Replace cord set.
- ANY INDICATION OF OVERHEATING OR SMOKE. Disconnect unit from wall socket immediately and call manufacturer.
- TYPING ON DIE-IMPRESSION STENCIL. Set the typewriter on stencil position or remove the ribbon. Type on the colored side of the stencil, then remove the backing to mark.



WARRANTY

The MARK 300 POWER UNIT is warranted to be free from defects in material and workmanship for a period of one year from the date of purchase. This warranty does not cover defects resulting from accident; alteration, improper use, abuse, tampering or failure of the user to follow operating instructions.

This warranty is in lieu of all other, warranties expressed, implied or statutory and all other obligations or liabilities of Marking Methods, Inc.



MARKING METHODS, INC.®

email: experts@markingmethods.com www.markingmethods.com

301 SOUTH RAYMOND AVENUE • ALHAMBRA CA 91803-1531 • (626) 282-8823 • FAX (626) 576-7564

